

Classic

UPDATES & MONTE NEWS



WELCOME

We had a great response from the crews who took part in Des Cols D'Ecosse. This event was to be a one-off but because of its success Oliver and I are working on a 2023 edition and we hope that it will be just as popular as the 2022 event. It will start and finish in Perth with an overnight in the Highlands. As well as following Scotland's legendary rally roads, we will incorporate a couple of motorsport venues. We have pencilled it in for the end of March. Watch this space.

Following our tribute to the late Willy Cave in the last newsletter, club member Richard Ward, kindly sent an article about an occasion in 2020 when he was thrilled to be navigated by Willy on the 30th Reunion Tour of the Monte Carlo Challenge. We have reproduced Richard's article for you in this newsletter.

On one of my trips south I had the good fortune of being given a guided tour of Gerry and Robert Wainwright's Motorsport workshop. This father and son team restore Historic Grand Prix and Sports Cars. It is a very impressive outfit. On the front of this month's cover you can see one of the Historic GP cars that they are preparing for the Monaco Historic Grand Prix. There is an article on my visit in this edition of the newsletter as well as the next instalment of the Lotus Farina story.

Now that the weather is improving it is time to get the classic out and ready to run through the summer. Hope to see you all at some time in the next few months.

Douglas Anderson
dglanderson1@yahoo.co.uk





farina

Engine Options B Series Twin-cam

The first option for our Lotus Farina would effectively be an off the shelf BMC power unit. The B series twin-cam engine. This engine was first used in an MGA in 1955 and raced at the TT in Dundrod that year. It also later powered the famous MG EX 179 and the EX 181 stream-lined record breaking cars which were successful in the International Class F record attempt on the Utah salt flats. The EX 181, in addition to the twin-cam cylinder head was also super charged, so this engine has a good motor sport pedigree.

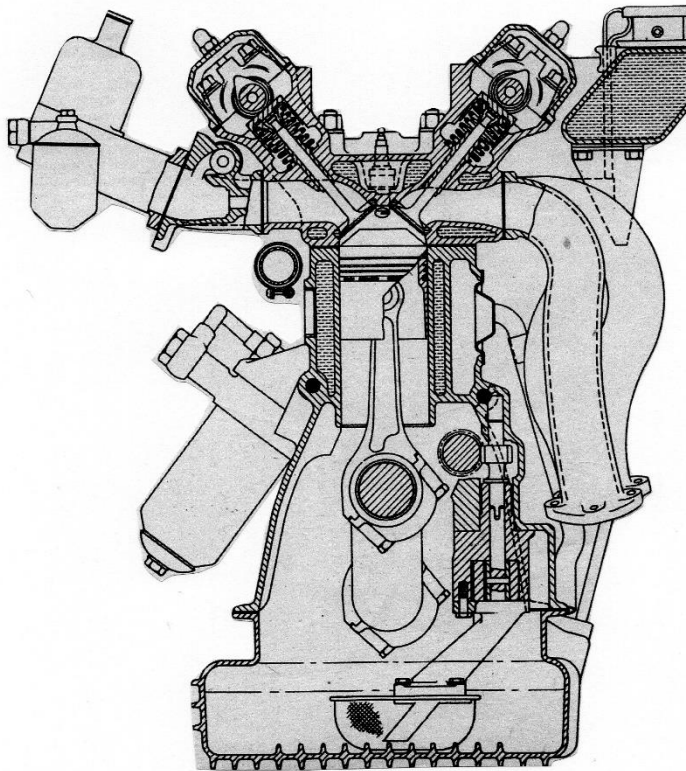

In production form, the twin-cam engine was installed in what became the MGA twin-cam. The capacity of this engine (1588cc) made it competitive in the 1600cc class.

In everyday use, it was not the most reliable of engines. It suffered from burnt valves and used large quantities of engine oil and so acquired a bad reputation. In its favour it produced a healthy 110bhp in standard form with a matching high torque figure.

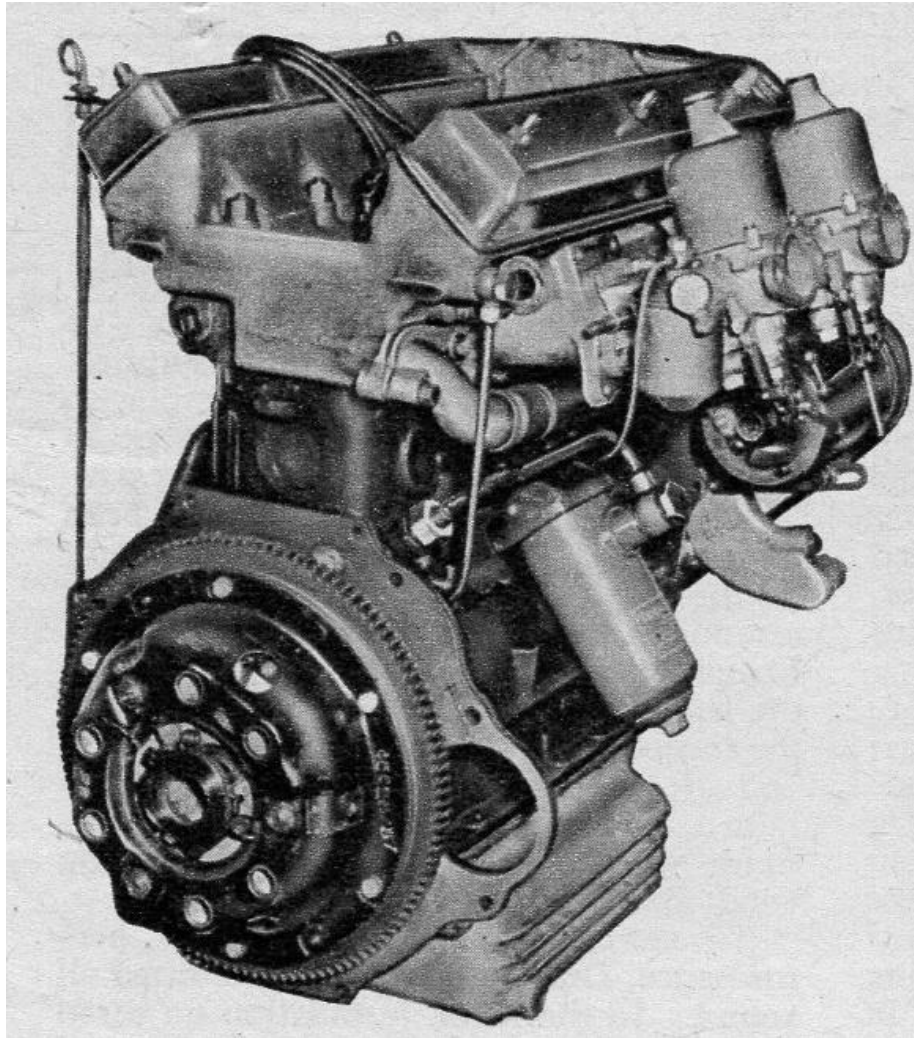

Although it had an aluminium cylinder head the engine was heavier than the standard B series engine. No doubt this engine could have been developed further with time and money, but it is significant that it was never offered as an option in the later MGB model range.

In the next issue of Classic Updates we will look at a much more exciting power unit which would have transformed the performance of our Lotus Farina and made it unbeatable in its day.

Monte News

Grand Prix de Monaco Historique 2022

Later this month (May) the Grand Prix de Monaco Historique will be staged in the famous 'round the houses' street circuit. It is a spectacular event and in many ways it is more exciting than the Monaco GP. Because the older GP cars are narrower it allows overtaking.

A few months ago I had the pleasure of visiting the workshops of Gerry Wainwright Motorsport. The father and son team prepare and restore Historic Grand Prix and Classic Sports cars. Robert who is a very skilled engineer and fabricator showed me round their facilities. His father, Gerry, is a keen historic rally enthusiast and is currently building a Lotus Elan rally car.

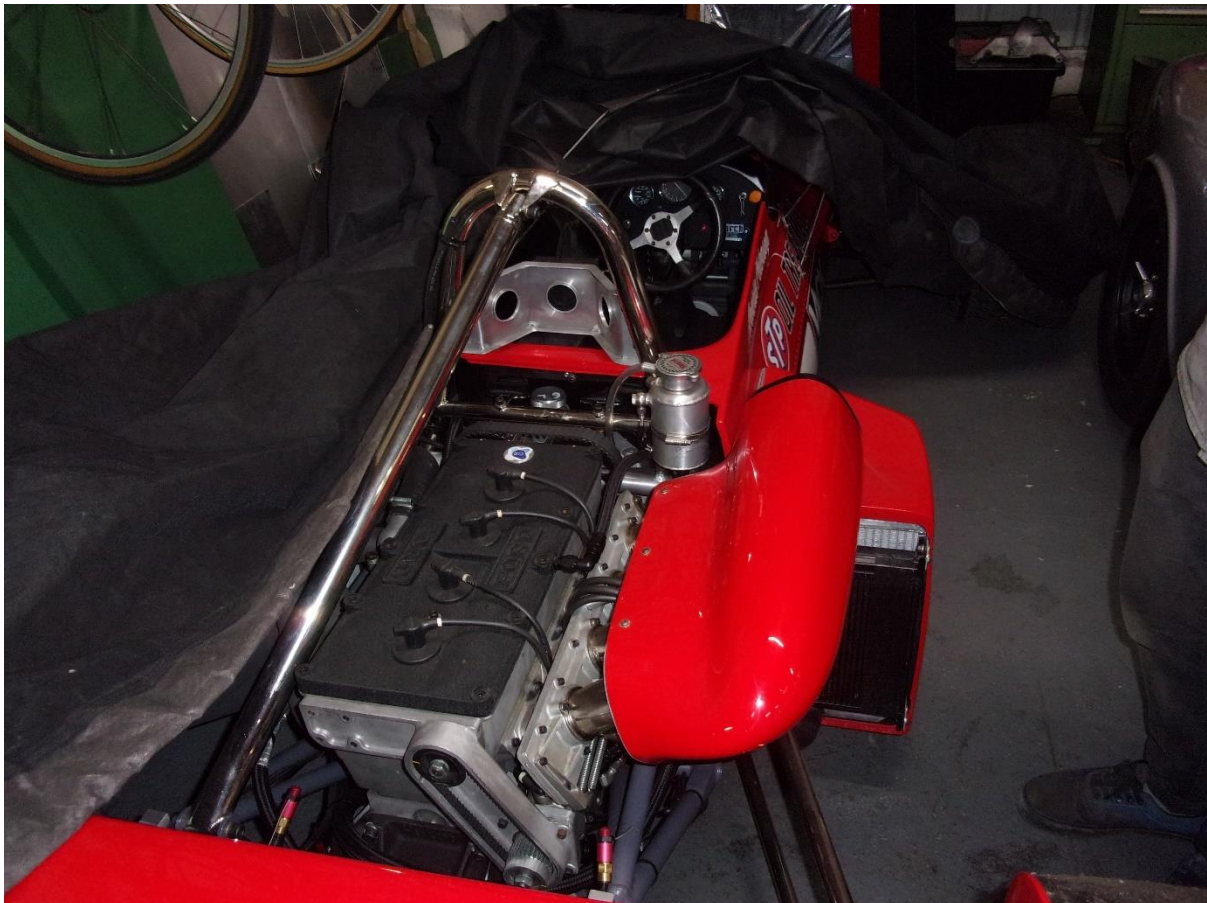

My visit turned out to be extremely informative and it was amazing to see how they go about restoring old Grand Prix cars. As you would expect, there are few chassis spares for these cars so many of the components have to be made from scratch. Their facilities are first class .



The shelves in the workshop are packed with all manner of jigs and components. Robert told me that they can make more or less anything for a Historic GP car, from small suspension components right through to complete aluminium monocoques. As long as they have either samples, drawings or photographs, they can make the part. Engines and gearboxes for rebuild are usually sub-contracted to specialists, although they can rebuild engines if necessary. If you are in the favourable position of having the wherewithall to restore a classic race car, you know where to go.



MY DAY WITH WILLY CAVE

Friday evening 24 January 2020, Bowcliffe Hall.

Richard Ward



I arrived at Bowcliffe Hall about 6pm for a very informal evening with past Monte Carlo Rally and Challenge competitors. We did a lot of talking. There were some fabulous bits of memorabilia that people had brought with them

and some videos of past rallies with loads of cheers when someone in the room happened to be on the screen. I met the gentleman who was to be my navigator the following day as Joy couldn't make it. We had a very enjoyable buffet in the Driver's Club, organised by Jonathan, who is a past entrant on the event and now the owner of the hall. The evening ended with people who lived close by returning home and the others returning to their hotel, the Mercure at Wetherby.

SATURDAY 25 JANUARY 2020

Leaving home in my 2004 Passat, the A1 was almost deserted as I headed up to Wetherby for the start of the 'Monte Carlo Challenge Reunion Tour', 180 miles of the best roads that North Yorkshire could offer. By 8am the car park was getting busy with people readying their cars. Frank Fennel was under the bonnet of his Volvo Amazon. Everyone was popping their rally plates on to a variety of types of cars. The cars ranged from a 1931 Alvis through to an almost new Mercedes with a plethora of MG's. There were a couple of VW's - Peter and Betty Banham's Golf and my Passat.



Car 1 was off at 08.30 and we were running car 21.....we, that is Willy Cave and I, in the Passat. Willy Cave, who did his first Monte Carlo Rally in 1955, the year I was born. Joy and I normally go through Jelly Babies midway between each tulip. This event was a bit different as we had a proper map

book with a marked route. We set off. Out to A1 North, we headed to Junction 50 and then over to Masham, Leighton Reservoir, Pately Bridge and a coffee stop at Grassington. Then over to Arncliffe, Gargrave, Slaidburn, to High Bentham, then onwards to Hawes for lunch via Ingleton and passing the Ribbleshead Viaduct.



Following Frank Fennel in his Volvo Amazon

After lunch at the Hawes Creamery, in the company of Jayne and Paul Wignall, we did Buttertubs Pass, then on to Keld, down Arkengarthdale, Reeth, Askrigg, Aysgarth, then back to Masham, and a nice steady run down the A1 to Wetherby, where tea was enjoyed with Robin Eyre-Maunsell. During the evening we had a nice meal followed by the prizegiving. We ended up being joint 3rd. Willy won a prize for being Willy and for his tenacity in getting to Wetherby.

What a lovely day. The roads were wet and mucky as you would imagine, but to spend the day with Willy Cave, who has navigated for the likes of Paddy Hopkirk, and John Sprinzel and has been a professional works team navigator for Triumph, Rover and BMC, was so special. We spent a lot of time while driving on the 'Transit Sections' talking about his life as a navigator. But he is more than that. He was in the Air Force as a Pilot, he worked for the BBC mainly as a Sound

Recordist, on Radio and TV. He was Alan Whicker's sound man. ['Whicker's World'] His first ever Radio recording as an interviewer was on a Monte Carlo Rally, interviewing the drivers as they re-started from Ye Olde Bell at Barnby Moor. He asked his Studio Manager if he could take a crew and cover the event from the re-start. It turned out to be well received by the BBC and the audience, and the BBC redistributed it to other radio stations around the globe.

In his childhood the family went to Europe, mainly on skiing holidays, and in later life he won various RAF skiing competitions. He was born in London and still lives there although he has spent many years while with the BBC living in Manchester, getting to know Northern England with his work and with rallying. You know people often say, 'Memories are made not bought'. Well, this day spent doing a run/tour with Willy Cave was very special and I am awfully thankful that I was able to be with him on this day. It is a very special memory and one I will cherish as I do realise how fortunate I have been.

Thanks have to go to Angela Riley & David Bull, the organisers, who teamed me up with Willy.

AND

Thank you to Willy for the day.

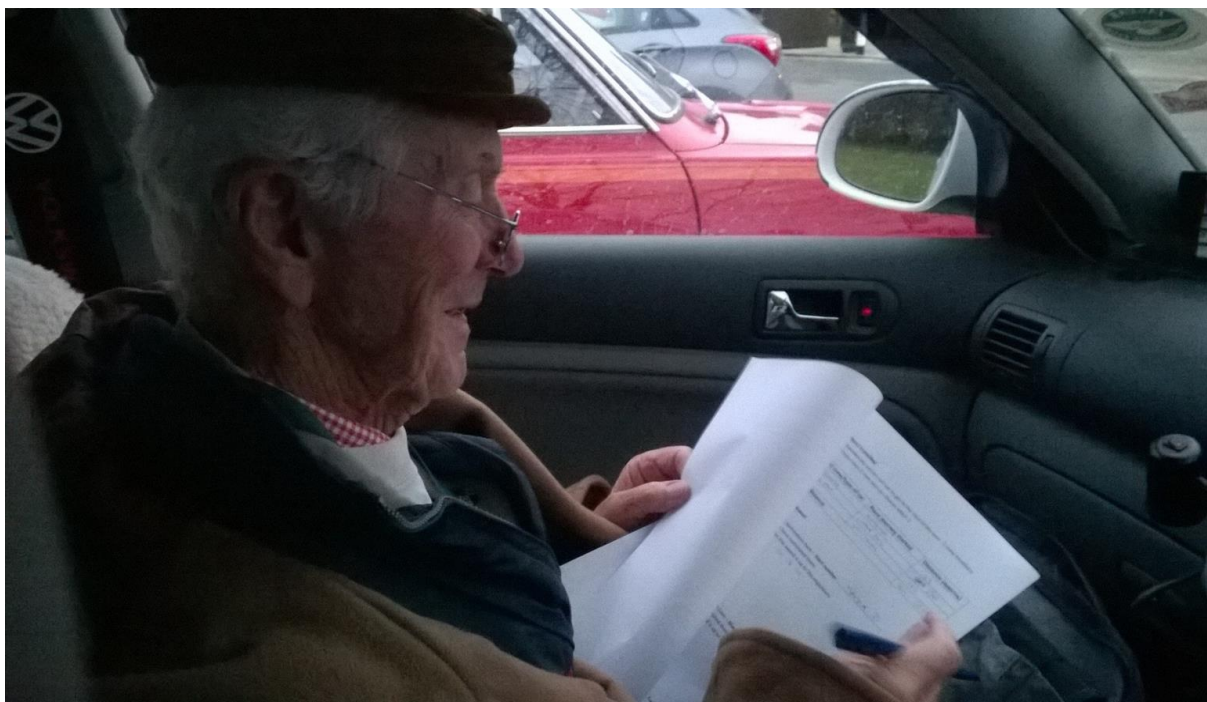

Willy in the 'Office' of RIW 7377

ERDC EVENTS 2022

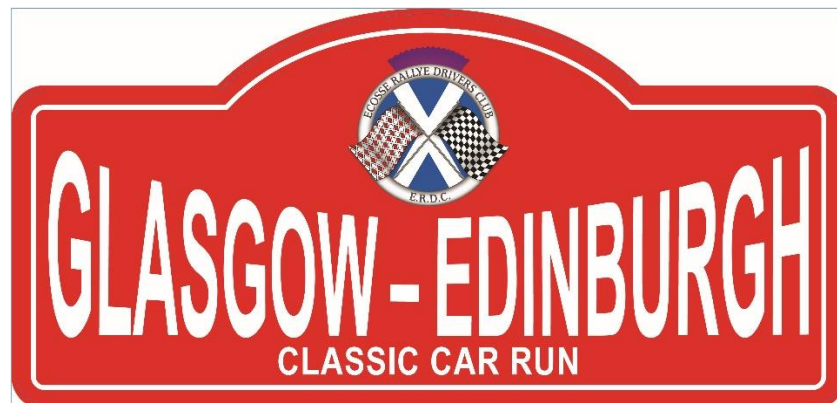
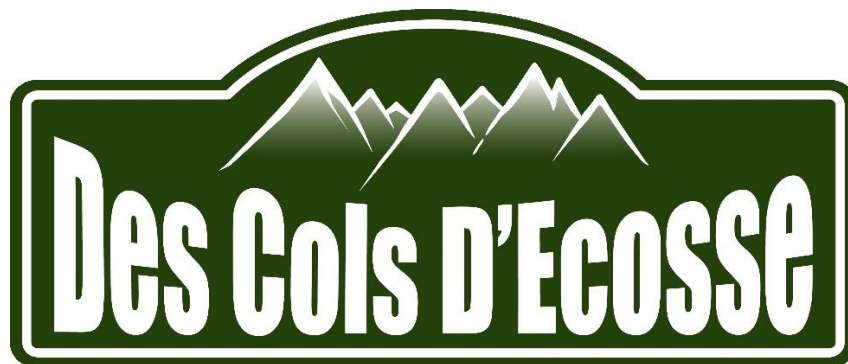

GLASGOW TO EDINBURGH RUN



Craig McGibbon is busy with the preparations for the forthcoming Glasgow to Edinburgh Classic Car Run which we hope to run in August. We are looking for a date that doesn't clash with events run by other clubs. The start will be in Glasgow with the opportunity to join the run in Stirling and Perth before going on to the finish in Edinburgh. The regulations and entry form will be out in July and notice will be given in forthcoming newsletters and on the ERDC tab of the www.monte.scot website.

